



HAMMER UNIONS



ABOUT CNC FLOW CONTROL

CNC Flow Control is headquartered in Houston, Texas with multiple other locations in the U.S. and Canada. Our company unifies several trusted valve and flow line brands that have been serving numerous industries in North America for nearly three decades. From long range projects to same-day delivery, our diverse team is dedicated to understanding customers' needs in order to ensure exceptional service and the best solutions. Our extensive product portfolio ranges from commodity products like hammer unions and needle valves, to highly engineered products like API 6D trunnion mounted ball valves.

Quality assurance is critical to CNC Flow Control's process and we hold multiple internationally recognized quality standards certifications and management system. We are dedicated to understanding our customers' needs to ensure exceptional service by offering an in-house engineering and product management team, an extremely large product portfolio and extensive inventory to support same day shipments.



















ABOUT OUR C&C BRAND

C&C's breadth of available products is extremely diverse. From hammer unions to ball valves, C&C products complement most any stocking portfolio. C&C has provided the market with quality valves and fittings for nearly three decades. Today, C&C products are seen in almost all upstream oil and gas applications throughout North America.

CONTENTS

HAMMER UNION FULL SCOPE OF OFFERING	02
HOW TO ORDER GUIDE	03
FIGURE 100	04-05
FIGURE 110	06-07
FIGURE 200	08-09
FIGURE 201	10
FIGURE 26H	11
FIGURE 206	12-13
FIGURE 207	14-15
FIGURE 211	16
FIGURE 300	17
FIGURE 301	18
FIGURE 400	19
FIGURE 602	20-21
FIGURE 607 (CGC)	22-23
FIGURE 1002	24-25
FIGURE 1003	26-27
FIGURE 1502	28-29
PRODUCT WARNINGS	30
NOTES	31
ABOUT OUR COMPANY	

HAMMER UNION FULL SCOPE OF OFFERING

FIGURE #	COLOR CODING	PRESSURE RATING (psi)		NOMINAL PIPE SIZES													
		Standard Service		0.5"	0.75"	1"	1.25"	1.5"	2"	2.5"	3"	4"	5"	6"	8"	10"	12"
		NSCWP	Test														
100		1,000	1,500						☺	☺	☺	☺	☺	☺	☺		
110		2,500 4,000	3,750 6,000						☺								
200		2,000	3,000			☺	☺	☺	☺	☺	☺	☺		☺	☺	☺	
201		3,000	4,000						☺	☺							
206		2,000	3,000			☺	☺	☺	☺	☺	☺			☺	☺	☺	
207		2,000	3,000							☺	☺			☺			
26H		400	800								☺						
211		2,000	3,000						☺		☺						
300		2,000 2,500 12,500	3,000 3,750 18,750	☺	☺	☺			☺								
301		3,000	4,500						☺								
400		4,000	6,000						☺		☺	☺					☺
602		6,000	9,000			☺		☺	☺	☺	☺	☺					
607 (CGC)		6,000	9,000					☺	☺								
1002		10,000	15,000			☺		☺	☺		☺	☺	☺	☺			
1003		7,500 10,000	11,250 15,000								☺	☺	☺				
1502		15,000	22,500			☺		☺	☺	☺	☺	☺	☺				

HOW TO ORDER GUIDE

EXAMPLE:

A 2", Figure 200, 2,000 PSI Rated Hammer Union with Threaded Ends with Stainless Steel Sub is written as U020200-SS.

A	B	C	D	E	F
U	020	2	0	0	-SS

A	Product Type
U	Hammer Union

B	Figure Number
010	Figure 100 - Economical
Y11	Figure 110 - Insulating
020 ¹	Figure 200 - 2,000 PSI
21	Figure 201 - EUE
260	Figure 206 - O-Ring Male Sub
270	Figure 207 - Blanking HU w/ O-Ring Female Sub
110	Figure 211 - Insulating
26H	Figure 26H - Hose Barb Union
030	Figure 300 - 2" Flat Face
Y30	Figure 300 - Flat Face (not 2")
210	Figure 301 - 3,000 PSI
040	Figure 400 - 4,000 PSI
620	Figure 602 - 6,000 PSI Fluid Flow Turbulence Reducing
C6	Figure 607 (CGC) - Guiberson Style
120	Figure 1002 - 10,000 PSI Fluid Flow Turbulence Reducing
130	Figure 1003 - Misaligning
150 ²	Figure 1502 - 15,000 PSI Fluid Flow Turbulence Reducing

C	Size ³
05	1/2"
75	3/4"
1	1"
125	1-1/4"
15	1-1/2"
2	2"
25	2-1/2"
3	3"
4	4"
5	5"
6	6"
8	8"
10	10"
12	12"

D	End Connection
0	Threaded (Standard End)
1	Schedule 40 BW
2	Schedule 80 BW
3	Schedule 160 BW
4	Extra Extra Heavy (XXH) BW
9	Misc

E	Misc Code
0	Complete Union
1	Male Sub Only
2	Female Sub Only
3	Nut Only (Combined with 9)
4	O-Ring Only (Combined with 9)
7	207 Cap Only (Combined with 9)

F	Special Suffix
(BLANK)	Standard
SG	Sour Gas Service - Figure 1502
-SS	Stainless Steel Subs - Figure 200
SW	Socket Weld - Figure 200

Warning: Metallic materials selected using ANSI/NACE MR0175/ISO 15156 are resistant to cracking in defined H2S containing environments in oil and gas production but not necessarily immune to cracking under all service conditions. It is the equipment user's responsibility to select materials suitable for the intended service.

1. For Figure 200 - 2,000 PSI Hammer Union with Stainless Steel Subs, add Special Suffix of -SS. Ex. U0202000-SS

2. To designate Hammer Union for Sour Gas Service (Figure 1502) add suffix SG.

3. Sizes do not always follow code designations (C).

C&C's Figure 100 is an economical union with precision machined metal-to-metal sealing surfaces. Recommended for water, oil and gas applications where working pressures do not exceed 1,000 PSI NSCWP.

* Interchangeable with other major manufacturers (see warnings on last page).



Specifications

- Sizes: 2" - 8"
- Pressure Rating: 1,000 psi NSCWP
- End Connections: Threaded & Butt-Weld
 - Butt-Weld Schedules: 40 (Std), 80 (XH)
- Color Code: Yellow Subs / Black Nut

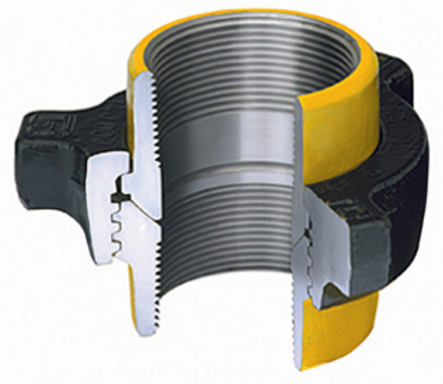

Standard Service	
NSCWP	Test
1,000 psi	1,500 psi

**All working pressures are Non-Shock Cold Working Pressure Ratings (NSCWP) at ambient temperatures (-20°F to 100°F)*

Threaded End Connections

Nominal Pipe Size	2"	2.5"	3"	4"	5"	6"	8"
Part #	U010200	U012500	U010300	U010400	U010500	U010600	U010800
Material (Sub)	A105	A105	A105	A395 D.I.	A395 D.I.	A395 D.I.	A395 D.I.
Material (Nut)	A105	A395 D.I.	A105	A395 D.I.	A395 D.I.	A395 D.I.	A395 D.I.
Clearance Radius (A)	2.91"	3.66"	4.00"	4.69"	5.20"	6.97"	7.67"
End to End (B)	3.63"	4.38"	5.07"	6.24"	6.58"	7.10"	8.60"
Approx. Weight (lbs)	6.1	10.8	14.5	22.4	31.0	47.0	60.0
Box Quantity	16	8	6	4	2	1	1

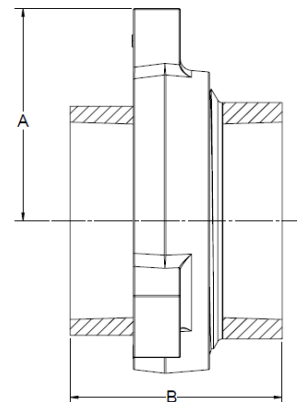

Butt Weld End Connections (Schedule 80*)

Nominal Pipe Size	2"	3"	4"	6"	8"
Part #	U010220	U010320	U010420	U010620	U010820
Material (Sub)	A105	A105	A105	A105	A105
Material (Nut)	A105	A105	A395 D.I.	A105	A395 D.I.
Clearance Radius (A)	2.91"	4.00"	4.69"	6.97"	7.67"
End to End (B)	3.79"	4.80"	4.98"	7.56"	7.31"
BW Sch 80 I.D. (ØC)	1.939"	2.900"	3.826"	5.761"	7.625"
BW Sch 80 O.D. (ØD)	2.375"	3.500"	4.500"	6.625"	8.625"
Approx. Weight (lbs)	6.6	16.0	23.5	54.0	80.0
Box Quantity	16	6	4	1	1

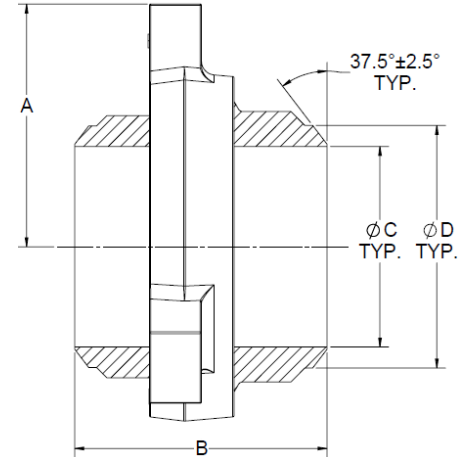

* Schedule 40 is available upon request



C&C's Figure 110 is recommended for use in piping systems where isolation of electrical current may be required, such as when cathodic protection is applied to a piping system in order to mitigate corrosion. The metallic components are separated by two insulating rings, one of which also functions as a sealing member. Materials used for insulating the connection and the double BUNA o-ring arrangement used for sealing are constructed of high quality materials that are resistant to most of the process fluids and chemicals that are routinely encountered during oil and gas production.



* Interchangeable with other major manufacturers (see warnings on last page).

Specifications

- Sizes: 2"
- Pressure Rating: 2,500 & 4,000 psi NSCWP
- End Connections: Threaded
- BUNA-N o-ring (-20°F to 250°F)
- Color Code:
 - 2,500 psi: Orange Subs / Orange Nut
 - 4,000 psi: Brown Subs / Brown Nut

Standard Service	
NSCWP	Test
2,500 psi	3,750 psi
4,000 psi	6,000 psi

**All working pressures are Non-Shock Cold Working Pressure Ratings (NSCWP) at ambient temperatures (-20°F to 100°F)*

Threaded End Connections

Nominal Pipe Size	2"	2"
Pressure Rating	2,500 psi	4,000 psi
Part #	UY11200B100	UY11200D100
Material (Sub)	A105	A105
Material (Nut)	A105	A105
Clearance Radius (A)	3.16"	3.94"
End to End (B)	3.70"	5.67"
Approx. Weight (lbs)	6.8	13.5
Box Quantity	12	6

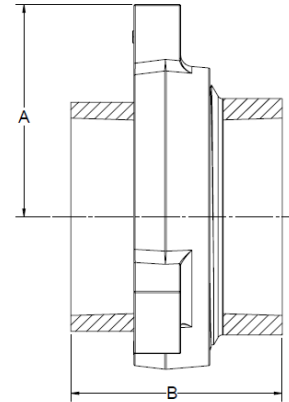

C&C's Figure 200 is a union of great utility. It meets most requirements in the medium pressure ranges. Precision seating surfaces assure dependable pressure seal. Recommended for water, oil and gas applications where working pressures do not exceed 2,000 PSI NSCWP.

* Interchangeable with other major manufacturers
(see warnings on last page)

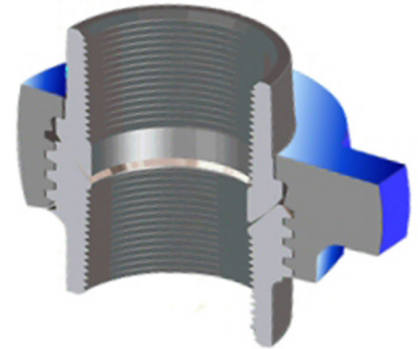

Specifications

- Sizes: 1" - 10"
- Pressure Rating: 2,000 psi NSCWP
- End Connections: Threaded, Butt-Weld & Socket Weld
 - Butt-Weld Schedules: 40 (Std), 80 (XH)
- Stainless steel also available
- Color Code: Gray Subs / Blue Nut

Standard Service	
NSCWP	Test
2,000 psi	3,000 psi

**All working pressures are Non-Shock Cold Working Pressure Ratings (NSCWP) at ambient temperatures (-20°F to 100°F)*

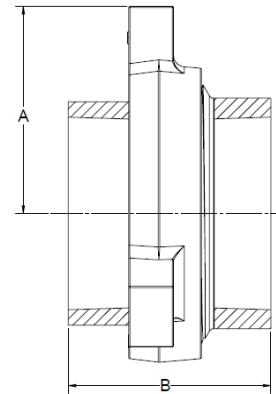

Threaded End Connections

Nominal Pipe Size	1"	1.25"	1.5"	2"	2.5"	3"	4"	6"	8"	10"
Part #	U020100	U021200	U021500	U020200	U022500	U020300	U020400	U020600	U020800	U021000
Material (Sub)	A105	A105	A105	A105	A105	A105	A105	A105	A105	A216 WCB
Material (Nut)	A105	A395 D.I.	A395 D.I.	A105	A395 D.I.	A105	A105	A105	A216 WCB	A216 WCB
Clearance Radius (A)	1.87"	2.50"	2.50"	2.91"	3.66"	3.96"	4.53"	6.125"	7.70"	8.98"
End to End (B)	2.65"	2.78"	2.85"	3.57"	4.31"	4.57"	5.04"	6.75"	7.31"	9.11"
Approx. Weight (lbs)	2.1	3.2	3.3	6.2	10.9	14.7	20.0	47.0	68.0	100.0
Box Quantity	40	30	30	16	8	6	4	1	1	1

Note: 316SS subs and socketweld ends also available

Butt Weld End Connections (Schedule 80*)

Nominal Pipe Size	2"	3"	4"	6"	8"	10"
Part #	U020220	U020320	U020420	U020620	U020820	U021020
Material (Sub)	A105	A105	A105	A105	A105	A216 WCB
Material (Nut)	A105	A105	A105	A105	A216 WCB	A216 WCB
Clearance Radius (A)	2.91"	3.96"	4.53"	6.125"	7.70"	8.98"
End to End (B)	3.79"	4.50"	5.03"	6.75"	7.31"	9.25"
BW Sch 80 I.D. (ØC)	1.939"	2.900"	3.826"	5.761"	7.625"	9.562"
BW Sch 80 O.D. (ØD)	2.375"	3.500"	4.500"	6.625"	8.625"	10.750"
Approx. Weight (lbs)	6.7	15.7	22.0	52.0	78.0	108.0
Box Quantity	16	6	4	1	1	1

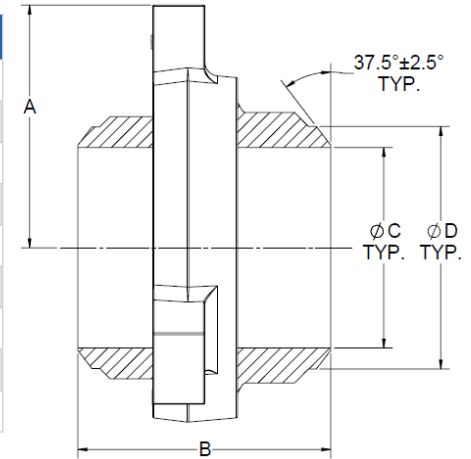

* Schedule 40 is available upon request



C&C's Figure 201 has EUE (External Upset Ends) 8 round tubing threads. This union is a Flat-Face type union that utilizes a BUNA o-ring seal. The Figure 201 is available in 2 3/8" EUE and 2 7/8" EUE and is recommended for water, oil and gas applications where working pressures do not exceed 3,000 PSI NSCWP.

* Interchangeable with other major manufacturers (see warnings on last page)



Specifications

- Sizes: 2" and 2.5"
- Pressure Rating: 3,000 psi NSCWP
- End Connections: 8 Round Threaded
- BUNA-N o-ring on female sub (-20°F to 250°F)

Standard Service	
NSCWP	Test
3,000 psi	4,000 psi

**All working pressures are Non-Shock Cold Working Pressure Ratings (NSCWP) at ambient temperatures (-20°F to 100°F)*

Threaded End Connections

Nominal Pipe Size	2"	3"
EUE API Size	2 3/8"	2 7/8"
Part #	U210250	U212550
Material (Sub)	A105	A105
Material (Nut)	A105	A105
Clearance Radius (A)	3.625"	4.00"
End to End (B)	5.50"	6.00"
Approx. Weight (lbs)	14.34	20.5
Box Quantity	6	4

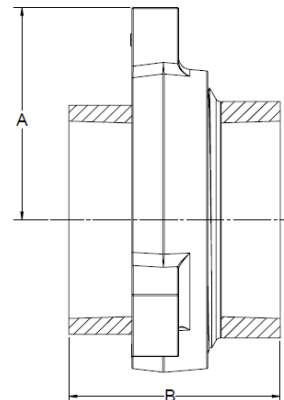

C&C's Figure 26H Frac Hose Fitting is often called a Hose Barb Union and is designed to save time and money by eliminating the need to weld a hose nipple onto a figure 200/206 hammer union. It features a union end connection that is interchangeable with a figure 200/206 connection, and it comes with an integral hose shank on both the male and female sub.

* Interchangeable with other major manufacturers (see warnings on last page).

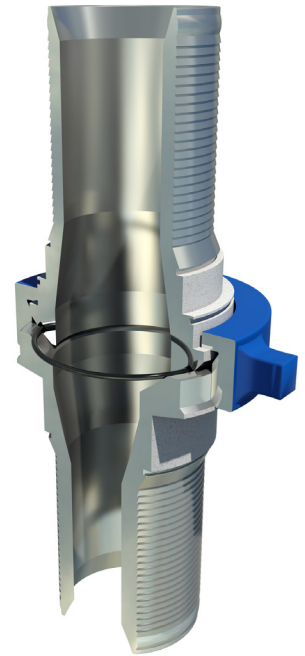

Specifications

- Sizes: 4"
- Pressure Rating: 400 psi NSCWP
- BUNA-N o-ring (-20°F to 250°F)
- Color Code: Electro zinc plated Subs / Blue Nut

Standard Service	
NSCWP	Test
400 psi	800 psi

**All working pressures are Non-Shock Cold Working Pressure Ratings (NSCWP) at ambient temperatures (-20°F to 100°F)*

Threaded End Connections

Nominal Pipe Size	3"
Part #	U26H400
Material (Sub)	A395 D.I.
Material (Nut)	A105
Clearance Radius (A)	4.53"
End to End (B)	16.47"
Approx. Weight (lbs)	30.0
Box Quantity	3

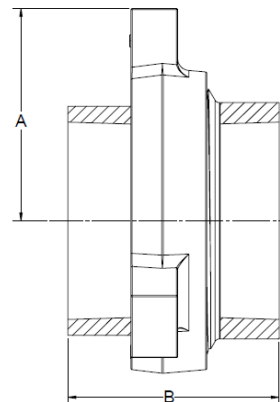

C&C's Figure 206 has a BUNA o-ring seal added to the male sub, which functions as a secondary seal. Recommended for water, oil and gas applications where working pressures do not exceed 2,000 PSI NSCWP. Subs and nuts of the Figure 206 union are interchangeable with the Figure 200.



* Interchangeable with other major manufacturers (see warnings on last page).

Specifications

- Sizes: 1" - 10"
- Pressure Rating: 2,000 psi NSCWP
- End Connections: Threaded, Butt-Weld & Socket Weld
 - Butt-Weld Schedules: 40 (Std), 80 (XH)
- BUNA-N o-ring on male sub (-20°F to 250°F)
- Color Code: Gray Subs / Blue Nut

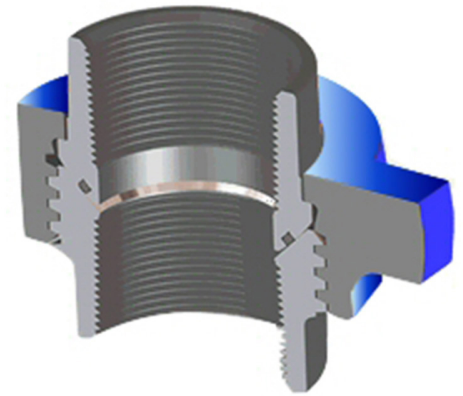

Standard Service	
NSCWP	Test
2,000 psi	3,000 psi

**All working pressures are Non-Shock Cold Working Pressure Ratings (NSCWP) at ambient temperatures (-20°F to 100°F)*

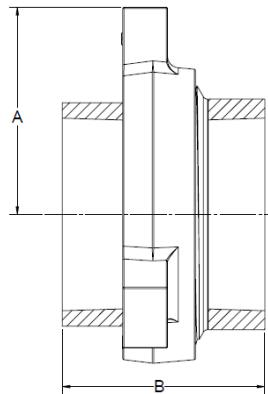

Threaded End Connections

Nominal Pipe Size	1"	1.25"	1.5"	2"	2.5"	3"	4"	6"	8"	10"
Part #	U260100	U261200	U261500	U260200	U262500	U260300	U260400	U260600	U260800	U261000
Material (Sub)	A105	A105	A105	A105	A105	A105	A105	A105	A105	A216 WCB
Material (Nut)	A105	A395 D.I.	A395 D.I.	A105	A395 D.I.	A105	A105	A105	A216 WCB	A216 WCB
Clearance Radius (A)	1.87"	2.50"	2.50"	2.91"	3.66"	3.96"	4.53"	6.125"	7.70"	8.98"
End to End (B)	2.65"	2.78"	4.875"	3.94"	4.31"	4.50"	5.08"	6.75"	7.31"	9.11"
Approx. Weight (lbs)	2.1	3.2	3.3	6.2	10.9	14.7	20.0	47.0	68.0	100.0
Box Quantity	40	30	30	16	8	6	4	1	1	1

Butt Weld End Connections (Schedule 80*)

Nominal Pipe Size	2"	3"	4"	6"	8"	10"
Part #	U260220	U260320	U260420	U260610S80	U260820	U261020
Material (Sub)	A105	A105	A105	A105	A105	A216 WCB
Material (Nut)	A105	A105	A105	A105	A216 WCB	A216 WCB
Clearance Radius (A)	2.91"	3.96"	4.53"	6.125"	7.70"	8.98"
End to End (B)	3.81"	4.57"	5.03"	6.75"	7.31"	9.25"
BW Sch 80 I.D. (ØC)	1.939"	2.900"	3.826"	5.761"	7.625"	9.562"
BW Sch 80 O.D. (ØD)	2.375"	3.500"	4.500"	6.625"	8.625"	10.750"
Approx. Weight (lbs)	6.7	15.7	22.0	52.0	78.0	108.00
Box Quantity	16	6	4	1	1	1

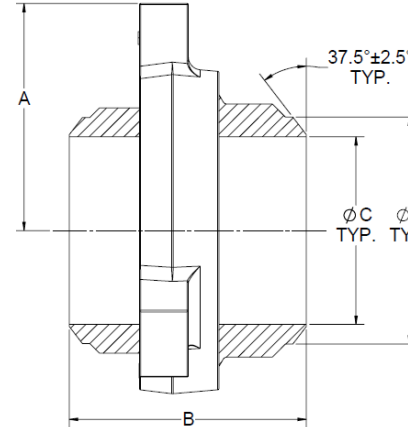

* Schedule 40 is available upon request

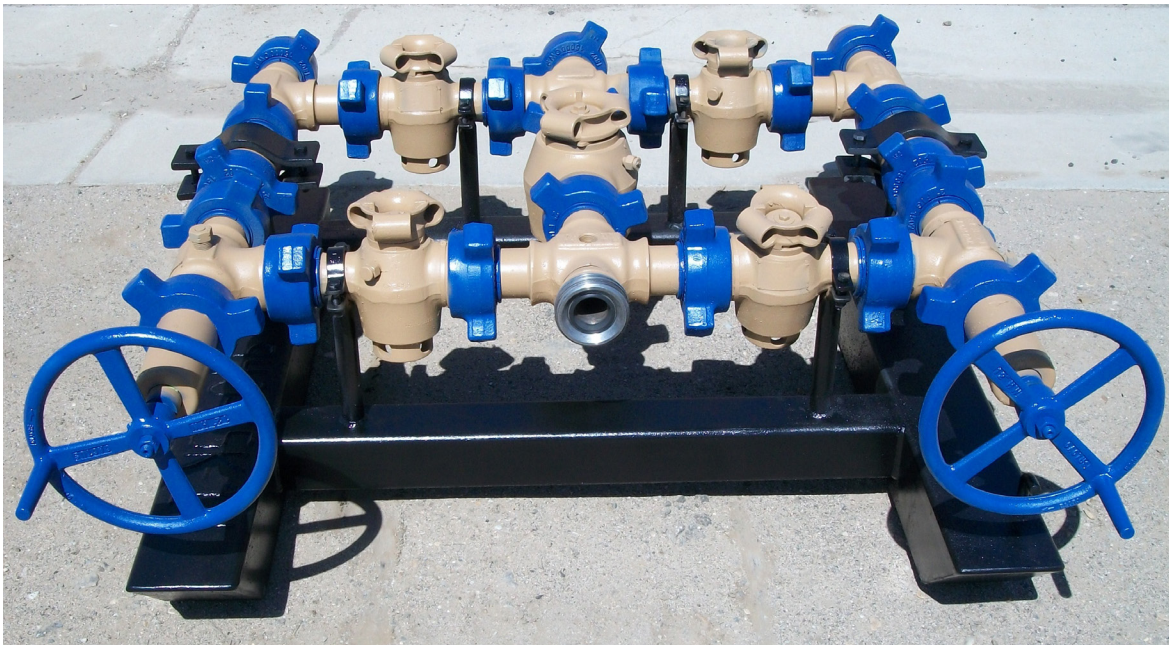

C&C's Figure 207 blanking union contains a Buna-N o-ring seal in the blanking cap to provide an efficient and dependable closure. The female sub is interchangeable with Figure 200 and 206 male sub and nut. Recommended for water, oil and gas applications where working pressures do not exceed 2,000 PSI NSCWP.

* Interchangeable with other major manufacturers (see warnings on last page).



Specifications

- Sizes: 3", 4", and 6"
- Pressure Rating: 2,000 psi NSCWP
- End Connections: Threaded and Butt-Weld
 - Butt-Weld Schedules: 40 (Std), 80 (XH)
- BUNA-N o-ring on blanking cap (-20°F to 250°F)
- Color Code: Gray Subs / Blue Cap

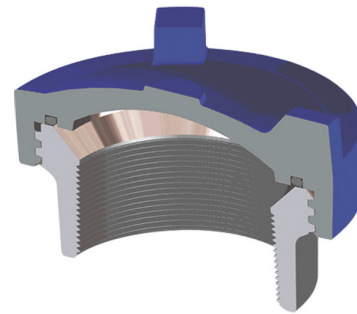

Standard Service	
NSCWP	Test
2,000 psi	3,000 psi

**All working pressures are Non-Shock Cold Working Pressure Ratings (NSCWP) at ambient temperatures (-20°F to 100°F)*

Threaded End Connections

Nominal Pipe Size	3"	4"	6"
Part #	U270300	U270400	U270600
Material (Sub)	A105	A105	A105
Material (Nut)	A105	A395 D.I.	A105
Clearance Radius (A)	2.88"	3.59"	4.96"
End to End (B)	3.75"	4.31"	5.69"
Approx. Weight (lbs)	10.6	18.8	41.2
Box Quantity	6	4	1

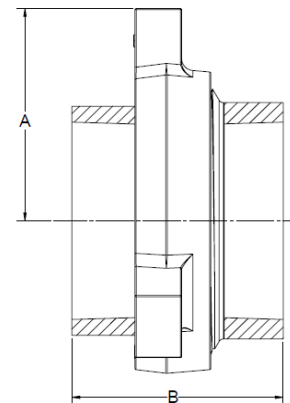

Butt Weld End Connections (Schedule 80)

Nominal Pipe Size	3"	4"
Part #	U270320	U270420
Material (Sub)	A105	A105
Material (Nut)	A105	A395 D.I.
Clearance Radius (A)	2.88"	3.59"
End to End (B)	3.75"	4.31"
BW Sch 80 I.D. (ØC)	2.900"	3.826"
BW Sch 80 O.D. (ØD)	3.500"	4.500"
Approx. Weight (lbs)	11.6	18.8
Box Quantity	6	4

* Schedule 40 is available upon request

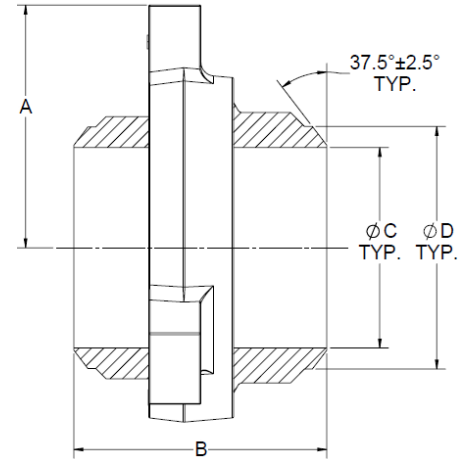

C&C's Figure 211 has insulating seals, eliminating metal to metal to contact and creating a positive seal. Recommended for 2,000 PSI systems where isolation of electrical current may be required, such as when cathodic protection is applied to a piping system in order to mitigate corrosion.

* Interchangeable with other major manufacturers (see warnings on last page).



Specifications

- Sizes: 2" and 3"
- Pressure Rating: 2,000 psi NSCWP
- End Connections: Threaded
- BUNA-N o-ring on male sub (-20°F to 250°F)
- Neoprene seal ring on female sub
- Color Code: Blue Subs / Gray Nut

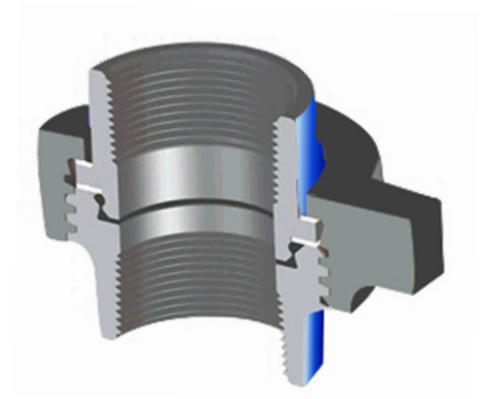

Standard Service	
NSCWP	Test
2,000 psi	3,000 psi

**All working pressures are Non-Shock Cold Working Pressure Ratings (NSCWP) at ambient temperatures (-20°F to 100°F)*

Threaded End Connections

Nominal Pipe Size	2"	3"
Part #	U110200	U110300
Material (Sub)	A105	A105
Material (Nut)	A105	A105
Clearance Radius (A)	2.91"	3.96"
End to End (B)	3.47"	4.47"
Approx. Weight (lbs)	6.9	14.0
Box Quantity	16	6

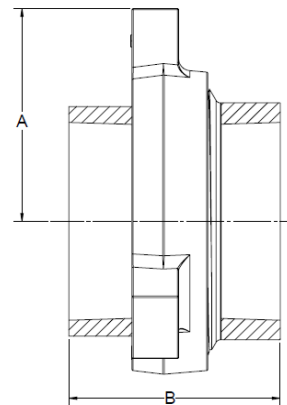



HAMMER UNIONS - FIGURE 300

C&C's Figure 300 is a Flat-Face type union that has a BUNA-N o-ring seal on the female sub. Recommended for use where straight breakout of pipe segments is required. Suitable for water, oil, or gas service at pressures up to 12,500 PSI NSCWP. Colors vary per pressure rating.

* Interchangeable with other major manufacturers (see warnings on last page).



Specifications

- Sizes: 0.5" - 2"
- Pressure Rating: 2,000, 2,500, and 12,500 psi NSCWP
- End Connections: Threaded
- BUNA-N o-ring on female sub (-20°F to 250°F)
- Color Code:
 - 2,000 psi: Yellow Subs / Black Nut
 - 2,500 psi: Gray Subs / Green Nut
 - 12,500 psi: Zinc-plated Subs / Zinc-plated Nut

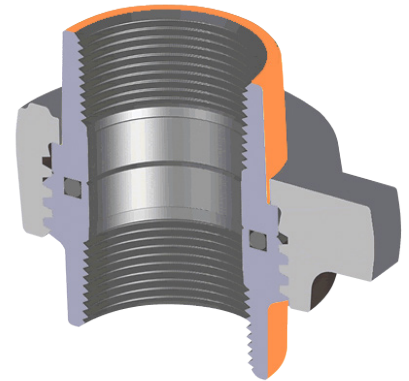

Standard Service					
NSCWP	Test	NSCWP	Test	NSCWP	Test
2,000 psi	3,000 psi	2,500 psi	3,750 psi	12,500 psi	18,750 psi

*All working pressures are Non-Shock Cold Working Pressure Ratings (NSCWP) at ambient temperatures (-20°F to 100°F)

Threaded End Connections

Nominal Pipe Size	0.5"	0.75"	1"	1"	2"
Pressure Rating	12,500 psi	12,500 psi	2,500 psi	12,500 psi	2,000 psi
Part #	UY30050G100	UY30075G100	UY30100C100	UY30100G100	U030200
Material (Sub)	SAE 4130	SAE 4130	A105	SAE 4130	A105 *
Material (Nut)	SAE 4140	SAE 4140	A105	SAE 4140	A105
Clearance Radius (A)	1.80"	1.80"	2.33"	2.52"	2.91"
End to End (B)	2.96"	3.08"	3.20"	3.53"	3.76"
Approx. Weight (lbs)	2.05	2.09	2.79	4.36	6.50
Box Quantity	40	40	32	16	16

*316SS subs also available

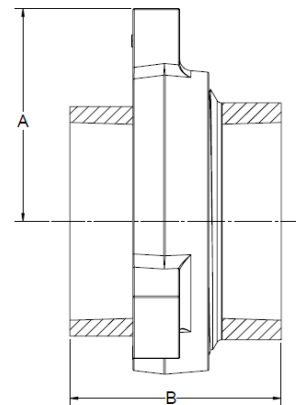

C&C's unique Figure 301 is a union of great utility with precision machined metal-to-metal sealing surfaces. It meets most requirements in the medium pressure ranges. Precision seating surfaces assure dependable pressure seal. Recommended for water, oil and gas applications where working pressures do not exceed 3,000 PSI NSCWP.

* Interchangeable with other major manufacturers (see warnings on last page).



Specifications

- Sizes: 2"
- Pressure Rating: 3,000 psi NSCWP
- End Connections: Threaded & Socket Weld
- Color Code: Gray Subs / Gray Nut

Standard Service	
NSCWP	Test
3,000 psi	4,500 psi

**All working pressures are Non-Shock Cold Working Pressure Ratings (NSCWP) at ambient temperatures (-20°F to 100°F)*

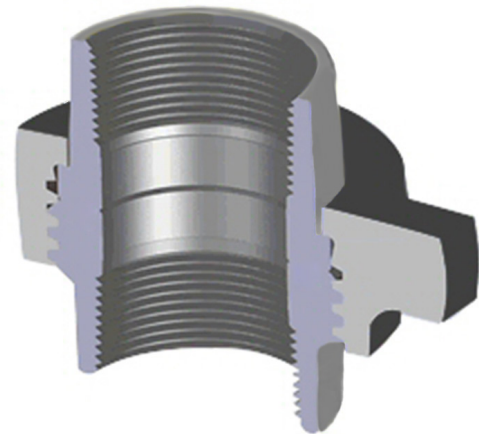

Threaded End Connections

Nominal Pipe Size	2"
Part #	U210200
Material (Sub)	A105
Material (Nut)	A105
Clearance Radius (A)	2.91"
End to End (B)	3.75"
Approx. Weight (lbs)	6.13
Box Quantity	16

Note: Socketweld ends also available

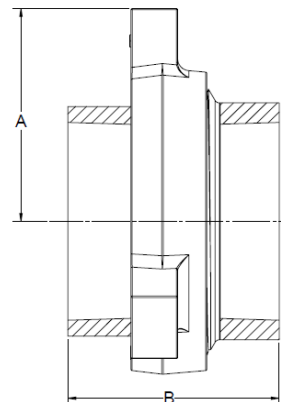

C&C's Figure 400 features a precision ball and cone sealing surface for sure metal-to-metal seal. Recommended for water, oil and gas applications where working pressures do not exceed 4,000 PSI NSCWP.

* Interchangeable with other major manufacturers (see warnings on last page).



Specifications

- Sizes: 2", 3", 4", and 12"
- Pressure Rating: 4,000 psi NSCWP
- End Connections: Threaded and Butt-Weld
 - Butt-Weld Schedules: 80 (XH)
- Color Code: Red Subs / Black Nut

Standard Service	
NSCWP	Test
4,000 psi	6,000 psi

**All working pressures are Non-Shock Cold Working Pressure Ratings (NSCWP) at ambient temperatures (-20°F to 100°F)*

Threaded End Connections

Nominal Pipe Size	2"	3"	4"	12"
Part #	U040200	U040300	U040400	U041200
Material (Sub)	A105	A105	A105	A105
Material (Nut)	1045	A105	A105	A105
Clearance Radius (A)	3.35"	4.125"	5.00"	10.39"
End to End (B)	5.39"	6.125"	8.125"	10.98"
Approx. Weight (lbs)	11.5	21.0	32.0	160.0
Box Quantity	6	4	3	1

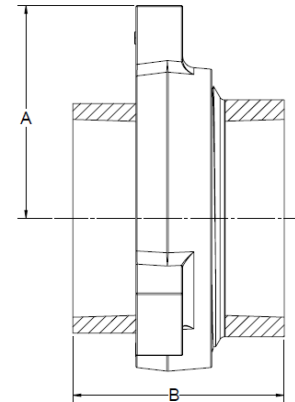

Butt Weld End Connections (Schedule 80)

Nominal Pipe Size	12"
Part #	U041220
Material (Sub)	A105
Material (Nut)	A105
Clearance Radius (A)	10.39"
End to End (B)	10.98"
BW Sch 80 I.D. (ØC)	11.374"
BW Sch 80 O.D. (ØD)	12.750"
Approx. Weight (lbs)	188.0
Box Quantity	1

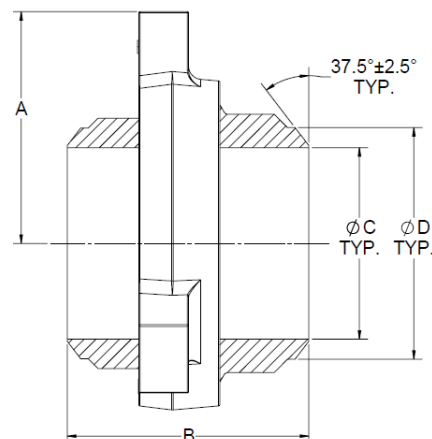

C&C's Figure Figure 602 is specifically designed to minimize fluid flow turbulence. The BUNA-N replaceable lip-type seal ring that provides this capability also provides a pressure seal and protection for the metal-to-metal seating surfaces. These unions are recommended for manifold and truck mounting where size and weight are critical, as well as air, water, oil, gas or mud service where working pressures do not exceed 6,000 PSI NSCWP.



* Interchangeable with other major manufacturers (see warnings on last page)

Specifications

- Sizes: 1" - 4"
- Pressure Rating: 6,000 psi NSCWP
- End Connections: Threaded & Butt-Weld
 - Butt-Weld Schedules: 80 (XH), 160, and XXH
- BUNA-N lip-type seal ring (-20°F to 250°F)
- Color Code: Orange Subs / Black Nut

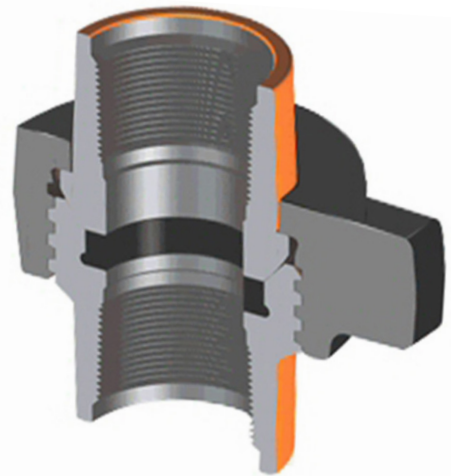

Standard Service	
NSCWP	Test
6,000 psi	9,000 psi

**All working pressures are Non-Shock Cold Working Pressure Ratings (NSCWP) at ambient temperatures (-20°F to 100°F)*

Threaded End Connections

Nominal Pipe Size	1"	1.5"	2"	2.5"	3"	4"
Part #	U620100	U621500	U620200	U622500	U620300	U620400
Material (Sub)	4130 AS	4140 AS	4130 AS	4130 AS	4130 AS	4130 AS
Material (Nut)	4140 AS	4140 AS	4140 AS	4140 AS	4140 AS	4140 AS
Clearance Radius (A)	2.15"	3.00"	3.60"	4.27"	4.50"	4.88"
End to End (B)	3.55"	4.88"	5.30"	6.16"	6.25"	8.13"
Approx. Weight (lbs)	3.9	10.8	15.0	18.7	26.7	37.0
Box Quantity	32	10	6	5	3	2

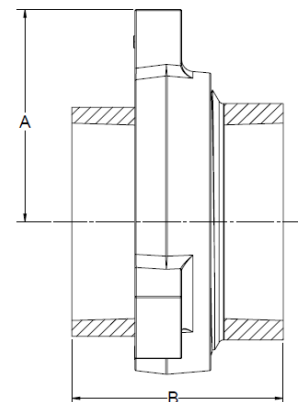

Butt Weld End Connections (Schedule 80*)

Nominal Pipe Size	2"	3"	4"
Part #	U620220	U620320	U620420
Material (Sub)	4130 AS	4130 AS	4130 AS
Material (Nut)	4140 AS	4140 AS	4140 AS
Clearance Radius (A)	3.60"	4.50"	4.88"
End to End (B)	5.09"	5.38"	5.63"
BW Sch 80 I.D. (ØC)	1.939"	2.900"	3.826"
BW Sch 80 O.D. (ØD)	2.375"	3.500"	4.500"
Approx. Weight (lbs)	17.0	28.0	36.0
Box Quantity	6	4	2

* Schedule 160 and XXH is available upon request

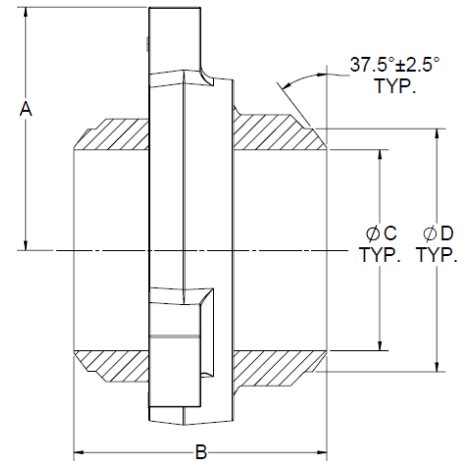

C&C's Figure 607 (CGC) is made with NPT ends and manufactured from forged low alloy steel. This union has BUNA-N "vee lip" type seal rings, and is commonly used in hot oil applications. The extended subs allow for quick breakout on manifolds and trucks. Recommended for water, oil and gas applications where working pressures do not exceed 6,000 PSI NSCWP.

*Interchangeable with other major manufacturers (see warnings on last page)



Specifications

- Sizes: 1.5" and 2"
- Pressure Rating: 6,000 psi NSCWP
- End Connections: Threaded
- BUNA-N vee lip type seal ring on female sub (-20°F to 250°F)
- Color Code: Silver Subs / Orange Nut



Standard Service	
NSCWP	Test
6,000 psi	9,000 psi

**All working pressures are Non-Shock Cold Working Pressure Ratings (NSCWP) at ambient temperatures (-20°F to 100°F)*

Threaded End Connections

Nominal Pipe Size	1.5"	2"
Part #	UC61500	UC60200
Material (Sub)	4130 AS	4130 AS
Material (Nut)	4140 AS	4140 AS
Clearance Radius (A)	2.83"	3.27"
End to End (B)	4.12"	5.78"
Approx. Weight (lbs)	7.5	12.7
Box Quantity	12	6

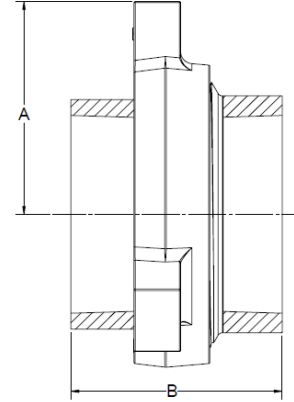

C&C's Figure Figure 1002 is specifically designed to minimize fluid flow turbulence. The BUNA-N replaceable lip-type seal ring that provides this capability also provides a pressure seal and protection for the metal-to-metal seating surfaces. These unions are recommended for use on high pressure systems and trucks, as well as air, water, oil, gas or mud service where working pressures do not exceed 10,000 PSI NSCWP.



* Interchangeable with other major manufacturers
(see warnings on last page)

Specifications

- Sizes: 1" - 6"
- Pressure Rating: 10,000 psi NSCWP
 - 5" threaded derated to 5,000 psi
 - 5" and 6" butt-weld derated to 7,500 psi
- End Connections: Threaded & Butt-Weld
 - Butt-Weld Schedules: 160 and XXH
- BUNA-N lip-type seal ring (-20°F to 250°F)
- Color Code: Blue Subs / Red Nut

Standard Service	
NSCWP	Test
10,000 psi	15,000 psi

**All working pressures are Non-Shock Cold Working Pressure Ratings (NSCWP) at ambient temperatures (-20°F to 100°F)*

Threaded End Connections

Nominal Pipe Size	1"	1.5"	2"	3"	4"
Part #	U120100	U121500	U120200	U120300	U120400
Material (Sub)	4130 AS	4140 AS	4130 AS	4130 AS	4130 AS
Material (Nut)	4140 AS	4140 AS	4140 AS	4140 AS	4140 AS
Clearance Radius (A)	2.15"	3.00"	3.60"	4.50"	4.88"
End to End (B)	3.55"	4.88"	5.30"	6.25"	8.13"
Approx. Weight (lbs)	3.9	10.8	15.0	26.7	38.0
Box Quantity	32	10	6	3	2

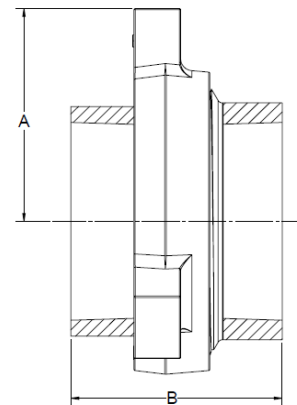

Butt Weld End Connections (Schedule XXH*)

Nominal Pipe Size	2"	3"	4"	5"	6"
Part #	U120240	U120340	U120440	U120540	U120640
Material (Sub)	4130 AS	4130 AS	4130 AS	4130 AS	4130 AS
Material (Nut)	4140 AS	4140 AS	4140 AS	4140 AS	4140 AS
Clearance Radius (A)	3.60"	4.50"	4.88"	6.00"	6.81"
End to End (B)	5.18"	5.38"	5.63"	6.13"	6.73"
BW Sch XXH I.D. (ØC)	1.503"	2.300"	3.152"	4.063"	4.897"
BW Sch XXH O.D. (ØD)	2.375"	3.500"	4.500"	5.563"	6.625"
Approx. Weight (lbs)	17.0	28.0	35.0	66.0	88.0
Box Quantity	6	3	2	1	1

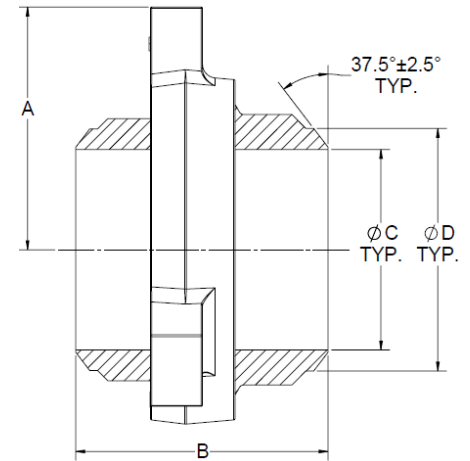

* Schedule 160 is available upon request

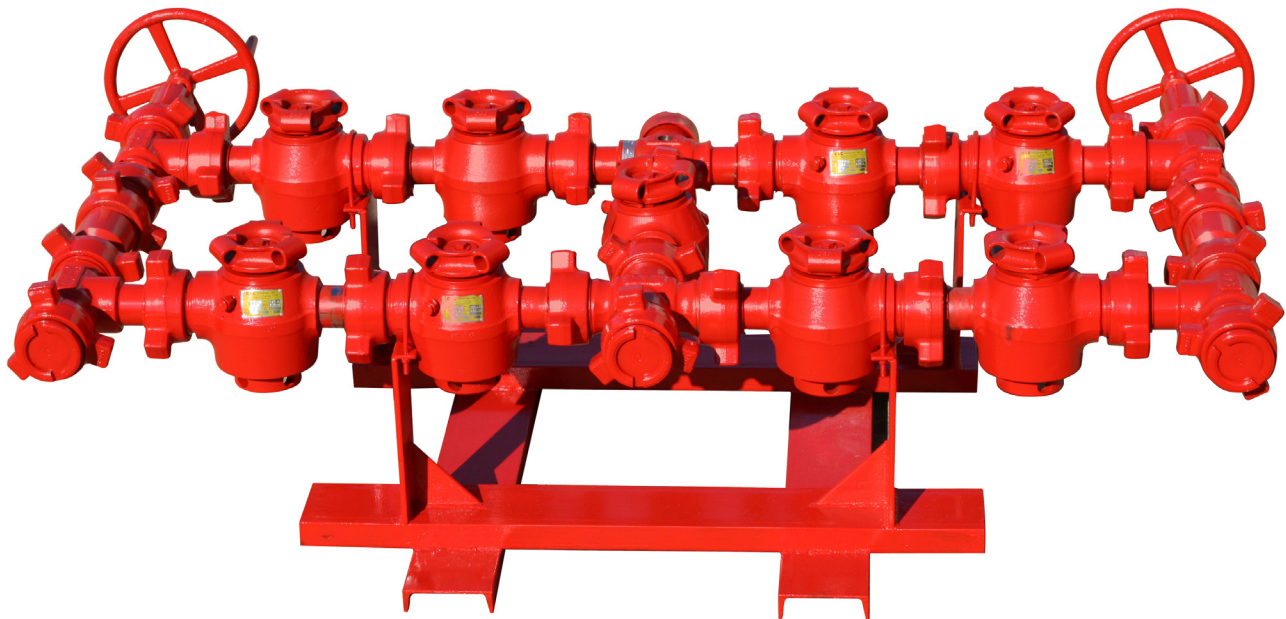

C&C's Figure 1003 is a Misaligning Union designed for systems in which piping alignment is a problem and needs up to a 7½° angular adjustment from the center (15° total). Recommended for high pressure water, oil, mud or gas applications where working pressures do not exceed 10,000 PSI NSCWP.

* Interchangeable with other major manufacturers
(see warnings on last page)



Specifications

- Sizes: 3" - 5"
- Pressure Rating: 10,000 psi NSCWP
 - 4" and 5" butt-weld rated to 7,500 psi
- End Connections: Butt-Weld
 - Butt-Weld Schedules: 160 and XXH
- BUNA-N lip-type seal ring (-20°F to 250°F)
- Color Code: Green Subs / Black Nut

Standard Service		
Size	NSCWP	Test
3"	10,000 psi	15,000 psi
4" and 5"	7,500 psi	11,250 psi

**All working pressures are Non-Shock Cold Working Pressure Ratings (NSCWP) at ambient temperatures (-20°F to 100°F)*

Butt Weld End Connections (Schedule XXH)

Nominal Pipe Size	3"	4"	5"
Part #	U130340	U130440	U130540
Material (Sub)	4130 AS	4130 AS	4130 AS
Material (Nut)	4140 AS	4140 AS	4140 AS
Clearance Radius (A)	4.88"	5.87"	5.96"
End to End (B)	9.13"	10.82"	10.94"
BW Sch XXH I.D. (ØC)	2.300"	3.152"	4.063"
BW Sch XXH O.D. (ØD)	3.500"	4.500"	5.563"
Approx. Weight (lbs)	44.5	79.0	80.0
Box Quantity	1	1	1

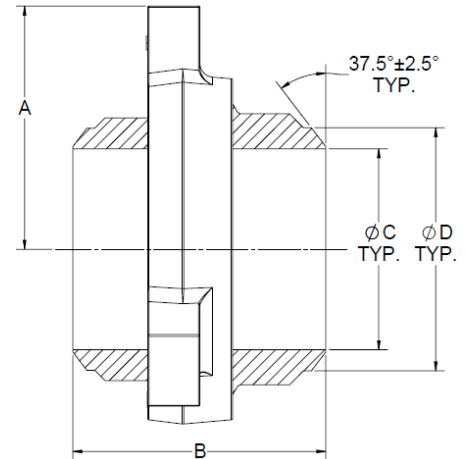

C&C's Figure 1502 is offered in both NACE and non-NACE and is specifically designed to minimize fluid flow turbulence. The BUNA-N replaceable lip-type seal ring that provides this capability also provides a pressure seal and protection for the metal-to-metal seating surfaces. These unions are recommended for manifold, truck mounting, and other installations where extreme high pressure is encountered where working pressures do not exceed 15,000 PSI NSCWP.

* Interchangeable with other major manufacturers
(see warnings on last page)



Specifications

- Sizes: 1" - 5"
 - NACE offering available in 2" and 3"
- Pressure Rating: 15,000 psi NSCWP
 - NACE derated to 10,000 psi
- End Connections: Threaded & Butt-Weld
 - Butt-Weld Schedules: 160 and XXH
- BUNA-N lip-type seal ring (-20°F to 250°F)
- Color Code:
 - Non-NACE: Red Subs / Blue Nut
 - NACE: Silver Subs / Green Nut



Standard Service		NACE Service	
NSCWP	Test	NSCWP	Test
15,000 psi	22,500 psi	10,000 psi	15,000 psi

*All working pressures are Non-Shock Cold Working Pressure Ratings (NSCWP) at ambient temperatures (-20°F to 100°F)

Threaded End Connections

Nominal Pipe Size	1"	1.5"	2"	2.5"	3"	4"
Part #	U150100	U151500	U150200	U152500	U150300	U150400
Material (Sub)	4130 AS	4130 AS	4130 AS	4130 AS	4130 AS	4130 AS
Material (Nut)	4140 AS	4140 AS	4140 AS	4140 AS	4140 AS	4140 AS
Clearance Radius (A)	3.00"	3.74"	3.74"	3.94"	4.50"	6.00"
End to End (B)	4.38"	4.52"	7.05"	7.26"	7.63"	8.50"
Approx. Weight (lbs)	9.1	19.2	20.0	22.6	34.7	76.0
Box Quantity	9	5	5	5	4	1

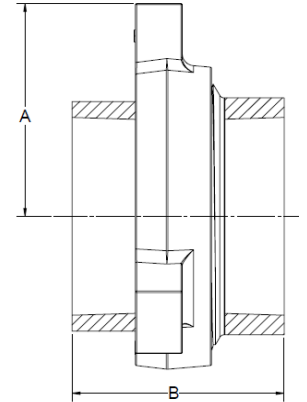

Butt Weld End Connections (Schedule XXH*)

Nominal Pipe Size	2"	3"	4"	5"
Part #	U150240	U150340	U150440	U150540
NACE Part #	U150240-SG	U150330SG	N/A	N/A
Material (Sub)	4130 AS	4130 AS	4130 AS	4130 AS
Material (Nut)	4140 AS	4140 AS	4140 AS	4140 AS
Clearance Radius (A)	3.74"	4.50"	6.00"	6.75"
End to End (B)	6.30"	5.25"	8.50"	9.00"
BW Sch XXH I.D. (ØC)	1.503"	2.300"	3.152"	4.063"
BW Sch XXH O.D. (ØD)	2.375"	3.500"	4.500"	5.563"
Approx. Weight (lbs)	20.0	30.0	84.0	96.0
Box Quantity	5	4	1	1

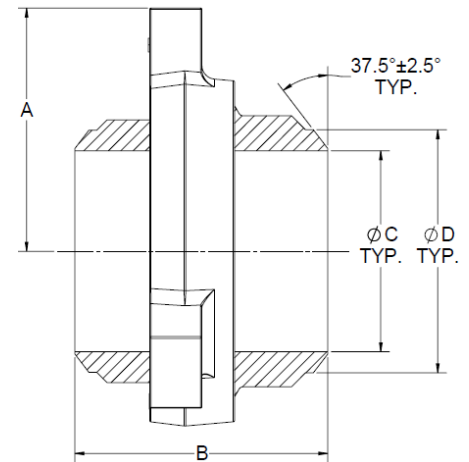

* Schedule 160 is available upon request

Failure to follow these warnings could result in failure and possible personal injury, death, or property damage:

- C&C products should be used only by qualified, trained individuals experienced in the safe and proper handling of hammer unions and other couplings. Users must follow all applicable specifications and industry best practices for the safe installation and use of C&C products.
 - Never exceed the recommended pressure rating or mix components with different pressure ratings, as mismatched components can lead to failure under pressure, resulting in death, personal injury, or property damage.
 - Never strike, tighten, or loosen pressurized components or connections.
 - Never exceed the non-shock cold rated pressure (NSCWP) of the product. Complete and proper assembly of all components and connections is essential in order to attain the rated NSCWP.
 - Never use any worn, eroded, or corroded components or connections. If any component of the union or connection is worn, eroded, or corroded, replace immediately.
 - Never strike hammer unions that have deformed or flattened lugs.
 - Never use C&C products in suspension applications.
 - Never expose standard service components or couplings to sour gas fluids. Do not interchange sour gas components or couplings with standard service components or couplings.
 - Always use extra care when working with carbon steel products in temperatures below 32°F/0°C. Freezing temperatures lower the impact strength of carbon steel.
 - Always take all appropriate safety precautions and wear all appropriate protective equipment when assembling, disassembling, installing, or removing any C&C product.
 - Always immediately remove from service any component or coupling from which leakage is detected.
 - Carefully select the appropriate component or coupling for your intended use.
 - Our standard unions are not dual certified for sour service/NACE applications. If you need a union for sour service/NACE applications, please let us know when you place your order.
- * If other manufacturers' components are used interchangeably, CNC Flow Control does not assume liability.

SERVICE CAPABILITIES



Trusted Partner. Reliable Solutions.

Our extensive product and application expertise allows us to be more than just a supplier. Our customers view us as the people they trust to integrate flow controls with their equipment and ensure the successful achievement of their project goals. Our increased involvement with a diverse range of projects, spanning an array of industries provides us with a multitude of references for successful integration.

PEOPLE

- Product and Application Know-How
- Technically Trained Sales Staff
- Exceptional Customer Service

PRODUCTS

- Ball, Butterfly, Check, Gate, Globe, Needle and Plug Valves, Adapters, Fittings, Gaskets, Joints, Couplings, Seals and Hammer Unions
- Product Leadership — Quality, Reliable and Innovative Products
- Replacement and Spare Parts
- ISO 9001:2015 Certified Organization

SERVICES

- Distribution Network Located throughout North, Central and South America
- Customer Specific Labeling and Packaging
- Strategic Account Partnerships
- Express Delivery
- Quality and Materials Assurance
- Valve Customization and Automation

Valve Quality Development Team

Before the decision is made to brand a product C&C, our Valve Quality Development Team conducts comprehensive manufacturers audits and inspections on both the product and the manufacturer's production and testing process. These stringent audits and inspections ensure the manufacturer's ability to produce and provide products of consistent quality demanded by our customers and in accordance with documented procedures. Once manufacturers are qualified, the VQDT performs onsite witnessing and inspections of the product prior to releasing it for shipment. This added capability and oversight differentiates us from other suppliers.



API 6D Pressure Test Capability

Reports providing proof of quality and testing are available to our customers. Additional tests can be provided upon request.

- Positive Material Identification
- Material Test Reports
- Non-Destructive Testing
- Quality and Technical Documentation
- Supplementary Testing per Customer Requirements



Proof of Product Quality and Compliance

About Our Company



CNC Flow Control is headquartered in Houston, Texas with multiple other locations in the U.S. and Canada. Our company unifies several trusted valve and flow line brands that have been serving numerous industries in North America for nearly three decades. From long range projects to same-day delivery, our diverse team is dedicated to understanding customers' needs in order to ensure exceptional service and the best solutions. Our extensive product portfolio ranges from commodity products like hammer unions and needle valves, to highly engineered products like API 6D trunnion mounted ball valves.



Quality assurance is critical to CNC Flow Control's process and we hold multiple internationally recognized quality standards certifications and management system. We are dedicated to understanding our customers' needs to ensure exceptional service by offering an in-house engineering and product management team, an extremely large product portfolio and extensive inventory to support same day shipments.

Headquarters

10350 Clay Road, Suite 250
Houston, TX 77041
Toll-Free: 844.398.6449

Permian Basin

1100 W IH 20
Odessa, TX 79763
Phone: 432.276.7640

Bakken Shale

4908 Highway 85
Williston, ND 58801
Phone: 701.572.0083

Canada

2930 51 Avenue NW, Unit # 3
Edmonton, AB T6P 0E1
Phone: 780.462.9166

Website: www.cncflowcontrol.com

Follow us:

